

VERTOT D. BEACH'S IMPROVED BOBBIN BORER.
 PATENTED

Fig. 1 DEC 3 1867

71683

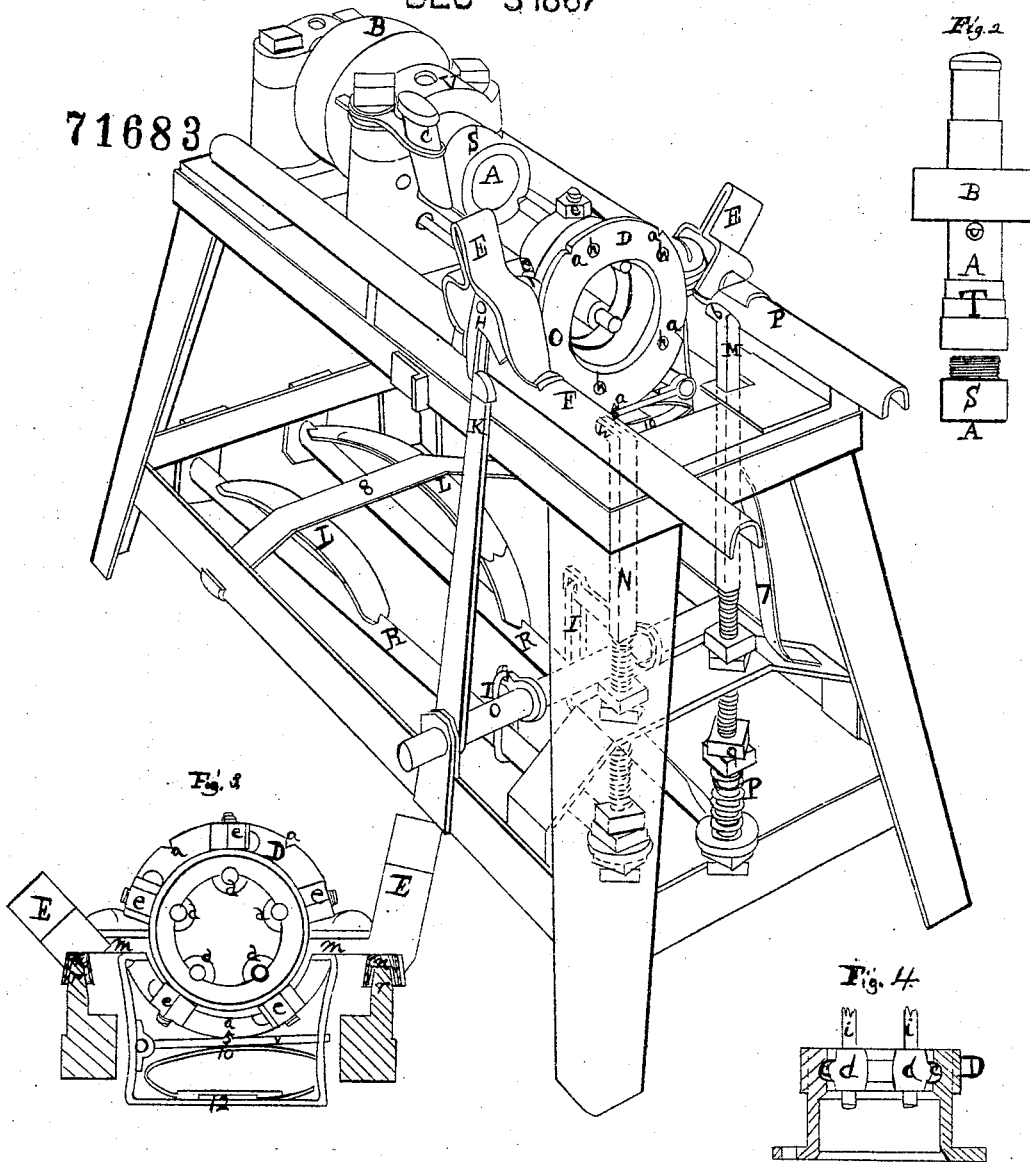

WITNESSES

R. J. Eberts
R. J. Eberts

INVENTOR

Vertot & Beach

United States Patent Office.

VERTOT D. BEACH, OF BATTLE CREEK, MICHIGAN.

Letters Patent No. 71,683, dated December 3, 1867.

IMPROVEMENT IN MACHINES FOR BORING BOBBINS.

The Schedule referred to in these Letters Patent and making part of the same.

TO WHOM IT MAY CONCERN:

Be it known that I, VERTOT D. BEACH, of Battle Creek, in the county of Calhoun, and State of Michigan, have invented a new Machine for Boring Bobbins; and I do declare that the following is an accurate description thereof, reference being had to the accompanying drawing and the letters of reference marked thereon, and being part of this specification.

Figure 1 is a perspective view of the machine.

Figure 2 is a top view of the mandrel.

Figure 3 is an end view of the bit-holder.

Figure 4 is a vertical sectional view of the same.

The same letters refer to the same parts of the machine in all the figures, 1, 2, 3, and 4.

This invention is designed for the purpose of boring bobbins or any other article of wood where a conical bore is desired. Upon a proper lathe-frame I erect a hollow mandrel, A, attached to the pulley B, upon which runs a belt to give power and motion. This mandrel A is constructed with a conical bore for the purpose of containing the piece of wood to be bored. This piece of wood revolving with the mandrel A at a high rate of speed, the stationary bit (hereinafter described) will follow the centre of motion in said piece of wood, and thereby produce a perfect bore. This mandrel A is constructed in two parts, as shown in the drawing, so that the part S may be withdrawn and a longer one substituted, for the purpose of holding a longer piece of wood. C is an oil-cup, containing a brush, which protrudes through the bottom, and oils each of the stationary bits before they are forced into the wood to be bored, which prevents clogging. The outside of the mandrel A is made with sectional bearings, as at T in fig. 2, which bearings are fitted to steps or shoulders in the journal-box V. At w, in fig. 2, is left a small orifice for the discharge of chips. The entire mandrel-head is so constructed that it can be moved backwards and forwards upon the frame, as may be required by different lengths of pieces of wood to be bored. The revolving bit-holder D is made of a cylindrical casting, as in fig. 3, attached by arms to *m m'* to the slides *n n'*. On top of the slides *n n'* are placed the light shields F F, to prevent chips or dust from settling upon the ways *v v'*, upon which the slides run. E E' are thumb-pieces or hand-rests, with which the operator moves his bit-holder forward or back, as occasion may require. This revolving bit-holder D has a chamber, as at *c c'*, fig. 4, which holds the clasps *d d'*, that attach the bits to the inside of the revolving bit-holder D. These bits are of different sizes and lengths, as may be required for the different articles to be bored. There are five bits and clasps *c c'*, each of a different size and length, and they are attached to the revolving bit-holder at *h h'*, &c., fig. 3. At *c c'*, &c., is placed a nut to tighten up the stem of the clasps *c c'* which stem passes through the shell of the bit-holder D. H, in fig. 1, is a dog, placed under the thumb-piece E, and acts upon the arm K, when the slides *n n'* are drawn back. The dog H, forcing the arm K back, turns the rock-shaft O, which is connected to the levers R R by the links I I. When the arm K is thus forced back, the levers R R are raised. To the levers R R are attached the rods M N. On the top of the rod N is attached a hook, W, that catches upon the bar *v*. Upon the top of this bar *v* is a stop, 5, which catches in the slots *a a*, &c., to hold the revolving bit-holder firm and steady, while the bits are being forced through the piece of wood to be bored. On drawing back the revolving bit-holder D, the hook *w* catches upon the bar *v* and releases the stop 5, and at the same instant, another hook, 6, upon the end of rod M, catches in the openings *h h*, &c., and revolves the bit-holder just one-fifth of a revolution, when the stop 5 stops it by entering again in the slot *a*, when the bit-holder is again ready to be moved up to force the next bit into the piece of wood to be bored. 7 is a leaf-spring, which holds the rod M in place while the hook 6 is acting upon the bit-holder D. L L are semi-elliptic springs fastened to the bridge 8, and act upon the levers R R, to throw them down instantaneously, and compel the hooks *w* and 6 to accomplish their work. 9 are nuts upon the rod M, to prevent its being thrown too high to allow the hook 6 to readily enter the openings *h*. P is a short spiral spring, which allows the lever R full play after the rod has been raised to its proper position. 10 is an elliptic spring attached to the cross-bar 12, which holds the bar *v* to its place.

What I claim as my invention, and desire to secure by Letters Patent, is—

1. The use of the oil-cup C, with the brush as described, for the purpose of oiling the reciprocating boring-bits.
2. The revolving bit-holder D, constructed and arranged to operate substantially as and for the purpose specified.
3. The arrangement of the dog H, the semi-elliptic springs L L, the levers R R, the rods M N, the hooks *w* and 6, the leaf-spring 7, the bar *v*, and the stop *s*, the links I I, the nuts 9, and the spiral spring P, arranged and operating substantially as and for the purposes specified.

VERTOT D. BEACH.

Witnesses:

H. F. EBERTS,

R. J. EBERTS.